

# **CITY THEATRICAL I N C**

752 EAST 133RD STREET BRONX, NY 10454

718/292/7932 FAX:718/292/7482

[www.citytheatrical.com](http://www.citytheatrical.com)



## **PDS-375 TR™ Touring Power Supply Operator's Manual**

Rev 1.0

© 2005 City Theatrical, Inc.

Patent Pending



## CONTENTS

The City Theatrical PDS-375 TR.....	3
Cautions.....	3
Compliance Certifications.....	3
Compatibility with Color Kinetics Equipment.....	3
Color Kinetics Fixtures Supported.....	3
Front Panel Controls.....	4
Back Panel Features.....	5
Mains Power Requirements.....	6
Connecting Color Kinetics fixtures to the PDS-375 TR.....	6
Operating Modes: CB, Pass Thru, or Stand-Alone.....	6
CB Mode.....	6
Pass Thru Mode.....	7
Stand-Alone Effects Mode.....	7
Using the Mini-Zapi.....	10
Installing the PDS-375 TR.....	10
Specifications.....	11

## FIGURES

Figure 1, PDS-375 TR, Front Panel.....	4
Figure 2, PDS-375 TR, Back Panel.....	5
Figure 3 PDS-375 TR with C-Clamp.....	10

## **The City Theatrical PDS-375 TR**

Thank you for using the City Theatrical PDS-375 TR™. Every effort has been made to anticipate your questions in this manual, but if you have any questions that we don't answer here, or you want to discuss a special application, please feel free to contact use directly at City Theatrical.

The CTI PDS-375 TR is a portable power supply unit provided with DMX 512 / Color Kinetics® data management circuitry. It is designed to provide 24VDC power and standard DMX512 distribution connections with DMX field addressing capability for Color Kinetics Fixtures, including ColorBlast® 6, ColorBlast 12, and iColor Cove® (other CK fixtures are also supported, check with your favorite lighting shop or City Theatrical for details).

### **Cautions**

The PDS-375 TR is intended for use only by qualified professionals. Connection, installation and hanging of this equipment must be performed in accordance with all pertinent local, regional and national safety codes and regulations.

The PDS-375 TR is intended for indoor use only.

Keep the unit dry! Do not operate the unit if it gets wet!

Do not operate in excessive heat/direct sunlight.

Be sure installation provides adequate ventilation. Both the front and the back side of the unit must be clear of obstruction and allow free airflow.

There are no user-serviceable parts inside! Refer to qualified service personnel!

### **Compliance Certifications**

ETL Listed, Conforms to UL 508A

cETL Listed, Certified to Can/CSA Standard 22.2 14-95

### **Compatibility with Color Kinetics Equipment**

The CTI PDS-375 TR and other CTI PDS products are produced under license and with the cooperation and approval of Color Kinetics Inc. and are the *only* such entertainment power supply and control systems approved for such use. City Theatrical, Inc. and Color Kinetics, Inc. have made every effort to assure that the CTI PDS-375 TR is fully compatible and will operate reliably with Color Kinetics fixtures.

### **Color Kinetics Fixtures Supported**

The PDS-375 TR will power and control the following Color Kinetics Fixtures:

- ColorBlast 12: 6 units, 1 per output
- ColorBlast 6: 12 units, 2 per output
- ColorBurst 6: 12 units, 2 per output
- ColorBurst 4: 24 units, 4 per output
- ColorSplash 2: 12 units, 2 per output
- iColor Cove: 48 units, 8 per output

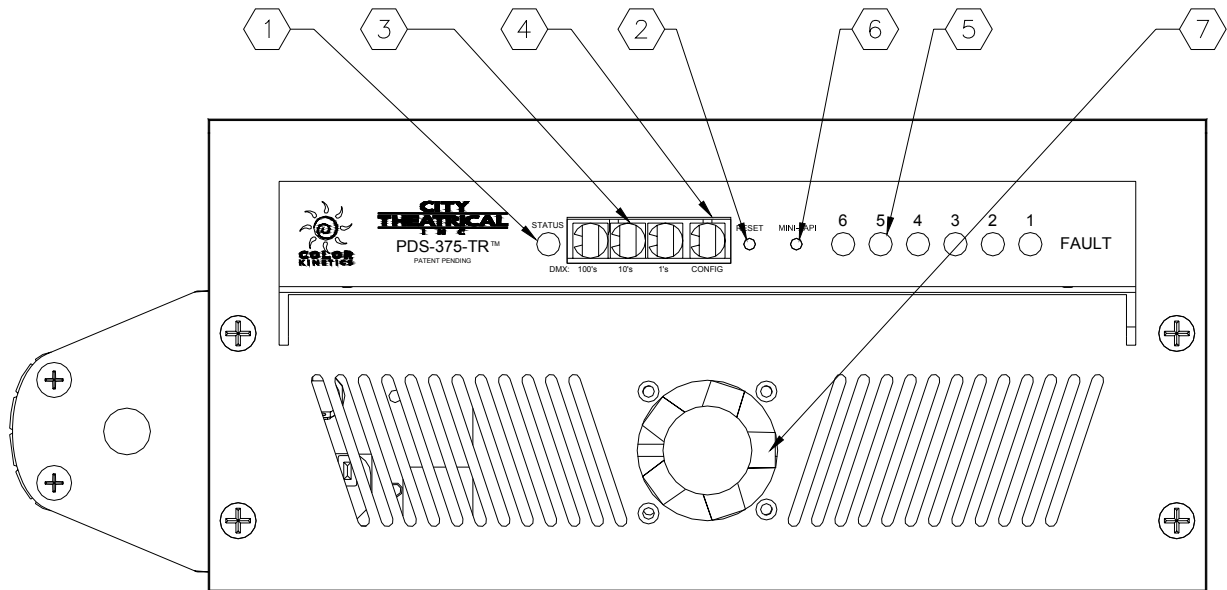

Figure 1, PDS-375 TR, Front Panel

### Front Panel Controls

The PDS-375 TR front panel controls will generally look familiar to most professional users, with a Pilot/Status Light, 3 BCD DMX Address Switch array, and a system reset switch. In addition, the unit is provided with a Configuration BCD, overload indicators, and a Mini-Zapi™ Switch. All the control functions are described below:

1. Pilot / Status Light:
  - On = Power Present, System running
  - Blinking = No DMX
  - Solid = DMX Present
  - Green = CB Mode
  - Orange = Pass Thru Mode
  - Alternating Red/Green = Stand Alone Mode
2. Reset Switch: Press to reset the PDS-375 TR's system microprocessor
3. DMX Address Switches: Left to right = 100's, 10's, 1's
  - Set address to 000 for Pass Thru mode
  - Set address to any valid address 001 – 476<sup>1</sup> for CB mode

<sup>1</sup> The unit may be addressed to start at *any* DMX value up to 512, however addresses above 476 will waste outputs, as DMX values will not exist for all outputs.

4. Configuration Switch: Selects Stand-Alone Routines. Also may be used for special functions
5. Channel Overload Indicator: Lights if internal circuit breaker is tripped, indicating an overloaded output. If tripped, disconnect load and allow unit to cool (~ 2 minutes). Circuit breaker will re-set. **Note: If internal circuit breaker trips, something is wrong. Correct fault before using system!**
6. Mini-Zapi™: Resets any connected Color Kinetics CB fixtures to *Light 001* (DMX 001,002 & 003), preparing them for easy use with the CB Mode setting
7. Fan, do not obstruct.

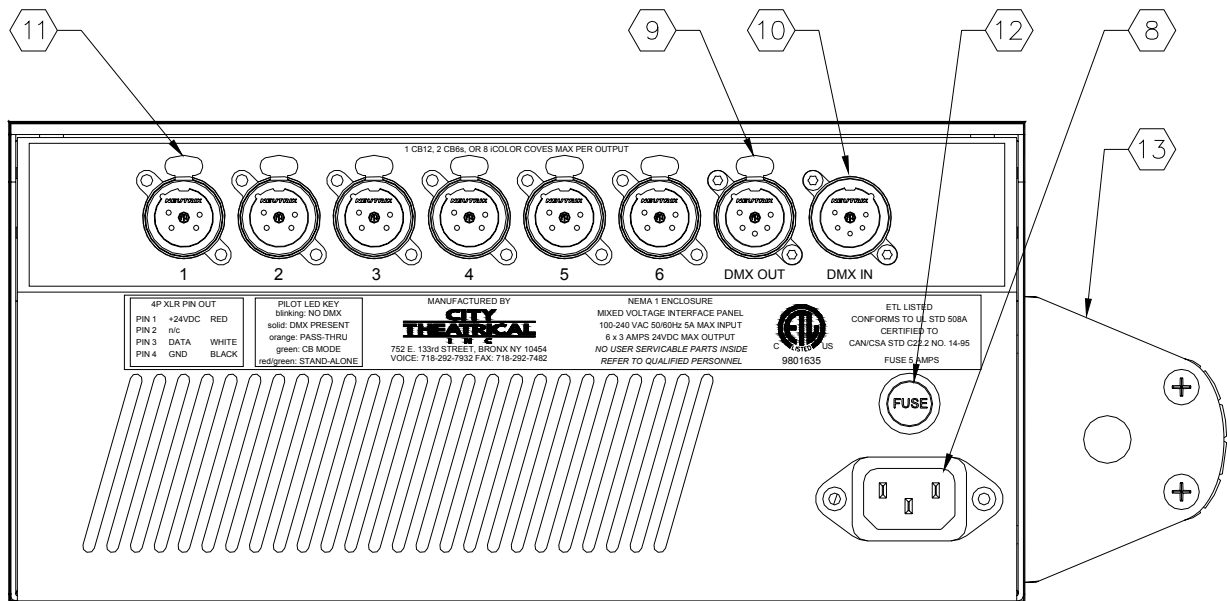

Figure 2, PDS-375 TR, Back Panel

### Back Panel Features

8. IEC Power Inlet, Connect Mains Power Cord here.
9. DMX OUTPUT, 5P XLR Female Panel Mount connector, a re-generated, optically isolated DMX output (the Unit switches to passive hard-wired pass-thru if power is lost).
10. DMX INPUT, 5P XLR Male Panel Mount connector, auto-terminated
11. Fixture Output # 1, 4P XLR Female, for connection of Color Kinetics fixtures
12. Fuse (5A 3AG)

13. Pipe Mount Handle.

**Mains Power Requirements**

The PDS-375 TR is compatible with 100-240 VAC, 50/60 Hz Mains Power. The unit is provided with a panel mount IEC Input connector for use with standard 100V – 240V cord sets.

**Connecting Color Kinetics fixtures to the PDS-375 TR**

The PDS-375 TR is provided with Female 4 pin XLR connectors for output connection to the CK fixtures. The connector pin out is as follows:

PIN #	Signal	CK Cable Wire Color
Pin 1	+24VDC	Red
Pin 2	(n/c)	
Pin 3	Data	White
Pin 4	DC Common	Black

Color Kinetics CB fixtures are provided with a permanently connected 60ft/20m cable. As 60ft/20m is the maximum length specified by Color Kinetics, this length should not be extended.

Color Kinetics manufactures an optional Data Amplifier/Repeater which may be inserted in the run if additional length is needed. Please contact City Theatrical or Color Kinetics for assistance and details.

**Operating Modes: CB, Pass Thru, or Stand-Alone**

The Unit can be configured for either DMX managed “**CB**” Mode, **Pass Thru** mode, or **Stand-Alone** Mode

**CB Mode**

In **CB Mode**, the system will route DMX (as CK Data protocol) to each output based on the selected DMX starting address. Each fixture is set as CK Light 1 (DMX 001, 002, 003). The PDS-375’s internal DMX Manager selectively routes DMX Data to each light output so that each light receives only the data packets that it is supposed to respond to. The effective DMX address of each fixture is a function of the starting address of the PDS-375, combined with the number of the output that fixture is connected to.

With the DMX Address set to 001: Fixture 1 = DMX 1, 2 & 3, Fixture 2 = DMX 4, 5, & 6, etc.

To put the unit into CB Mode, simply set the DMX Address switches to a desired address other than 000. The unit can be set to any valid DMX address, however please note that any starting address over 476 will disable some outputs.

**Configuration / system setup for CB (DMX managed) mode**

- 1 If necessary, Use the on-board Mini-Zapi (see Using the Mini-Zapi page 10) or Color Kinetics Zapi™ to pre-address all CB fixtures as DMX 001.
- 2 Plug up to 6 of those CB fixtures into outputs 1 – 6

- 3 Connect the System to a DMX source via the DMX Input and connect power
- 4 Set the system's DMX Address to the desired starting address value AAA
- 5 The 6 connected CB fixtures will respond as follows:

CB Fixture # 1 = DMX address AAA, AAA+1, AAA+2  
CB Fixture # 2 = DMX address AAA+3, AAA+4, AAA+5  
CB Fixture # 3 = DMX address AAA+6, AAA+7, AAA+8, etc.

### **Pass Thru Mode**

In **Pass Thru mode**, the system will convert all the DMX values to CK Data protocol, and send that CK Data (with 24V power) to all 12 outputs. This mode is useful when powering i-Color Cove fixtures which have local address switches for each light. The Pass Thru Mode can also be suitable for CB fixtures when using the CTI PDS-375 TR in a system requiring Zapi addressing schemes, such as when being used in combination with other Color Kinetics™ power supplies like the PDS-150™

Pass Thru Mode is selected whenever the DMX Address switches are set to all 0s (000) and the Config Switch is set to 0

### **Stand-Alone Effects Mode**

In **Stand-Alone Mode** the PDS-375 TR will run various pre-programmed effects without need for a console. This is very useful for events like parties or trade shows, where a constantly running program is desired without the use of a console or show programming.

The unit is placed into Stand-Alone Mode using the Config BCD switch. When the unit is in Stand-Alone mode, the DMX Address switches become Effect controls. Different Stand-Alone Effects are selected via different setting combinations of the DMX Address switches and the Config switch

### **Configuration Switch Settings for different Stand-Alone Effects**

- 0 No Stand-Alone function. The System will operate normally in Pass-Thru or CB Modes, depending on the DMX Address switch settings.
- 1 Fixed Color. The DMX address BCDs are used to adjust the red, green and blue components. DMX 100s controls the red (0 is off and 9 is full), DMX 10s controls green and DMX 1s controls blue.
- 2 Color Wash (forward). The color wash effect moves sequentially around the spectrum of colors (Red, Magenta, Blue, Cyan, Green, Yellow & White) repeating the same cycle over and over again at user definable speeds. The speeds are controlled by setting the DMX 10s & ones to 1 of 48 possible settings. The following lists their settings and approximate fade times.

0	.25 sec
1	.3 sec
2	.4 sec
3	.6 sec
4	1.25 sec
5	2.55 sec

6	4 sec
7	5 sec
8	10 sec
9	15 sec
10	20 sec
11	25 sec
12	30 sec
13	35 sec
14	40 sec
15	45 sec
16	50 sec
17	1 min
18	1.2 min
19	1.3 min
20	1.5 min
21	1.6 min
22	2 min
23	2.3 min
24	2.6 min
25	3 min
26	3.5 min
27	4 min
28	4.5 min
29	5 min
30	5.5 min
31	6 min
32	6.5 min
33	7 min
34	8 min
35	9 min
36	10 min
37	12 min
38	15 min
39	20 min
40	25 min
41	30 min
42	40 min
43	50 min
44	1 hr
45	1.5 hr
46	2 hr

- 3 Color Wash (reverse). Same as above but in counter clockwise rotation (White, Yellow, Green, Cyan, Blue, Magenta, & Red).
- 4 Cross-Fade. The Cross-Fade effect changes from one preset color to another than back again. The DMX 100s switch sets the starting color and the DMX 10s switch sets the ending color. The user specified speed is controlled by the DMX 1s switch. The following speeds are provided.



0	5 sec
1	10 sec
2	30 sec
3	1 min
4	2 min
5	15 min
6	30 min
7	1 hr

- 5 The random color effect produces random colors at user definable speeds. The randomly generated color steps from one to the next without and fading. Speed is controlled by the DMX 10s and 1s digits. The following speeds are provided:

0	.075 sec
1	.1 sec
2	.15 sec
3	.2 sec
4	.275 sec
5	.325 sec
6	.375 sec
7	.5 sec
8	.625 sec
9	.95 sec
10	1.25 sec
11	1.5 sec
12	1.875 sec
13	2.5 sec
14	3.125 sec
15	4.375 sec
16	5.625 sec
17	6.25 sec
18	9.375 sec
19	12.5 sec
20	15 sec
21	18.75 sec
22	31.25 sec
23	37.5 sec
24	56.25 sec
25	1.25 min
26	1.875 min
27	2.5 min
28	3.125 min
29	3.75 min

- 6 Fixed color strobe uses the DMX 100s switch to choose the color (1-Red, 2-Green, 3-Yellow, 4-Blue, 5-Magenta, 6-Cyan, 7-White, 8&9-Black). The strobe rate is controlled by the DMX 1s digit. The following rates are provided:

0	20/sec
1	13/sec

2	10/sec
3	7.5/sec
4	5/sec
5	4/sec
6	3/sec
7	2/sec

- 7 Variable color strobe steps from color to color (Red, Green, Yellow, Blue, Magenta, Cyan, & White) in a user definable time period at a strobe rate that is also user definable. The same strobe rate that is employed in the fixed color strobe is available via the DMX 1s digit. The step times between color changes are provided via the DMX 100s and 10s switches. The values and time periods are the same as the random color effect.

### Using the Mini-Zapi

CB fixtures can be quickly re-addressed as “Light 1” (DMX 001, 002, & 003) using the Mini-Zapi.

1. Power Up the PDS-375 TR
2. Place the PDS-375 TR into Pass-Thru Mode
3. Connect the CB Fixture(s) to the PDS-375 TR.
4. Press the Mini-Zapi button.
5. The CB fixture(s) will light red for a moment and then flicker for a few seconds.
6. After the flickering stops, Power the system down.
7. Power the system back up to test the units.

### Installing the PDS-375 TR

The PDS-375 TR can be mounted to a pipe or truss using a standard theatrical C-clamp. The unit is provided with a ½” hole in the center of the handle for attaching the C-clamp, and with holes in the handle base for a safety cable. When mounting the PDS-375 TR in this way, all necessary care should be taken to assure that the installation is suitable and safe, and that the hardware is properly rated for the task.

The PDS-375 can also be setup on a table, shelf, or other suitable flat surface. Be sure that adequate clearance for ventilation is maintained. Do NOT seal the PDS-375 up in a box or other un-cooled enclosure. If environmental protection is required, the unit may be installed in a suitable and *properly ventilated* NEMA 3R enclosure. Contact City Theatrical for details.



Figure 3 PDS-375 TR with C-Clamp

## Specifications

**Dimensions:** 12.785" W (with handle), 5.031" H, 6.828" D

**Weight:** 9.5 Lbs.

### Electrical Specifications:

- Input Power 100-240VAC 50/60 Hz 600 Watts
- Output Power 24VDC 14 Amps Max

### Features:

- Heavy Duty NEMA 1 Steel and Aluminum enclosure
- 100-240 VAC 50/60hz Mains Power (auto-ranging)
- Mounting points for C-Clamp & Safety Cable
- (6) 4P XLRF CK Data/24V Power output connectors for fixture connection
- DMX 512 Interface (see below)
- 1 x 600 Watt internal power supply
- 24VDC 3A current limited per circuit output with LED Fault Indication
- One-touch Mini-Zapi feature for reconfiguring fixtures with correct starting DMX Address
- Includes 7 types of user-configurable fade and chase routines for stand-alone operation
- In Stand-Alone Mode, selected routine is output to DMX Pass-Thru for synchronized Stand-Alone operation of many CB Supply systems

### DMX 512 Interface:

- DMX Input via 5P XLR Male
- Isolated and repeated DMX Pass-Thru via 5P XLR Female
- DMX Address interface utilizing 3 Rotary BCD Switches for DMX Address configuration

### CK Output Configuration

- 6 outputs providing Color Kinetics control protocol, +24VDC, and Ground
- "CB Mode": DMX converted to CK protocol and output selectively to each port as per BCD address setting (see below)
- "iCove Mode": All 512 DMX values converted to CK Protocol and output on all ports

### Compliance

- ETL Listed, Conforms to UL 508A
- cETL Listed, Certified to Can/CSA Standard 22.2 14-95

**\*Fixtures Supported:** ColorBlast 12, ColorBlast 6, ColorBurst 6®, ColorBurst 4®, iColor Cove®