

# Pathport QUATTRO

## User Guide

August 2011



© Pathway Connectivity 2011  
1439 17 Ave SE Calgary AB T2G 1J9  
403-243-8110  
[www.pathwayconnect.com](http://www.pathwayconnect.com)



## Table of Contents

About Pathport Quattro .....	3
Installation Instructions .....	3
Protocols Supported .....	4
Front Panel Controls .....	5
Rear Panel .....	5
Front Panel Display.....	6
Setting Node Properties.....	7
Note Regarding ArtNet, Shownet and Subnet Mask.....	7
Setting Port Properties.....	8
Advanced Configuration.....	8

## About Pathport Quattro

Pathway Connectivity's Pathport® QUATTRO is a four-port DMX-over-Ethernet node intended for use primarily in entertainment lighting systems. The Quattro provides transparent transmission and receipt of the DMX512 lighting control standard, using a number of widely accepted protocols, across a standard Ethernet data network.

The Quattro may be used alone, networked other Quattro and Pathport nodes, as well as with a number of other Ethernet-aware lighting control products, such as consoles and controllers.

The Quattro, like all Pathports, is a routing device and does not provide control over the protocols or the data being passed. It only provides control over the path the data takes, how multiple DMX sources are treated (merged or prioritized), and certain other routing characteristics including DMX transmission speed and signal loss behavior.

## Installation Instructions

The Pathport Quattro is intended for desktop use, or for mounting in a standard 19" equipment rack, using the rack ears included.

Truss-mount adaptors (#9004) and wall-mount kits (#9005) are also available.

The Pathport Quattro is intended for installation in a dry, indoor location. Operating conditions: 0°C - 40°C; 10-90% relative humidity, non-condensing.

**Warning:** The AC socket outlet shall be installed near the equipment and shall be easily accessible.

**Warning:** This equipment relies on building installation primary overcurrent protection.

**Warning:** Except for the IEC chassis plug marked for AC input, all ports on the Pathport Quattro are intended for low voltage data lines only. Attaching anything other than low voltage sources to the data ports may result in severe equipment damage, and personal injury or death.

## Protocols Supported

### DMX512

The most widely used digital multiplex protocol for controlling entertainment lighting and effects equipment. The DMX signal consists of 512 8-bit control packets sent asynchronously over a two-pair shielded cable at 250K Baud. The standard connector type is 5 pin XLR. The standard has been revised several times over the years, with the latest being ANSI E1.11 DMX512-A (2005). The Pathport Quattro is designed to work seamlessly with all variants of the protocol.

DMX is a last mile protocol, daisy-chained between end fixtures.

### Ethernet Protocols

Ethernet protocols are used to multiplex DMX data over Ethernet networks, largely to circumvent control channel limitations inherent in the DMX standard. The Pathport Quattro supports the most widely accepted.

Pathport Protocol: A broadcast protocol developed by Pathway Connectivity and implemented by a variety of console manufacturers.

ArtNet: A broadcast protocol developed by Artistic Licence. Its free distribution has made it popular with media server manufacturers. Because this is not a standard, some implementations may not work with others.

Strand Shownet: A proprietary broadcast protocol developed by Strand Lighting and used exclusively in Strand lighting consoles.

ANSI E1.31 streaming ACN (sACN): A multicast industry standard developed and maintained by the Technical Standards Program of the Entertainment Services and Technology Association (ESTA). The standard is available for a nominal cost from ESTA. This standard provides the DMX512 data transport for the separate ANSI E1.17 ACN (Architecture for Control Networks) industry standard.

sACN is the transport used by ETC Net3. The Quattro is fully compliant with Net3, and will seamlessly receive either Final Draft 20, or the ANSI approved versions of sACN.

### Remote Device Management

ANSI E1.20 Remote Device Management is an industry standard, also published by ESTA, which allows remote configuration of last-mile DMX devices, using the same wire pair that carries the DMX signal. Like DMX, RDM requires a separate dedicated controller to generate the signal packets the Quattro will route. Pathport Manager 5.1 now includes an RDM management interface tab.

## Front Panel Controls

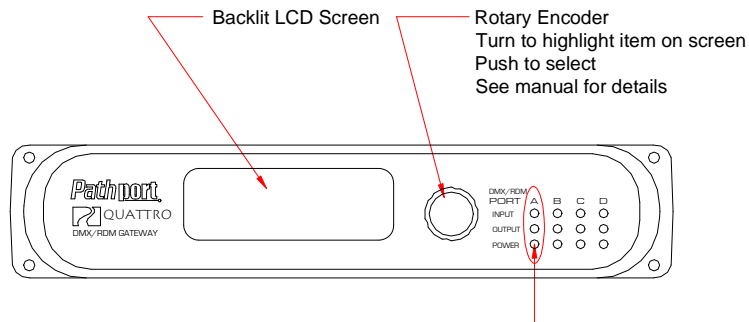

LED Indicator Chart - Indicators apply on a port-by-port basis			
Colour	Label	Action	Explanation
RED	INPUT	Flashing	No Data Present
		Steady On	Valid DMX Received
GREEN	OUTPUT	Flashing	No Data Present
		Steady On	Valid DMX Transmit
BLUE		Steady On	Port Active/Patched
		Off	Port Disabled

## Rear Panel

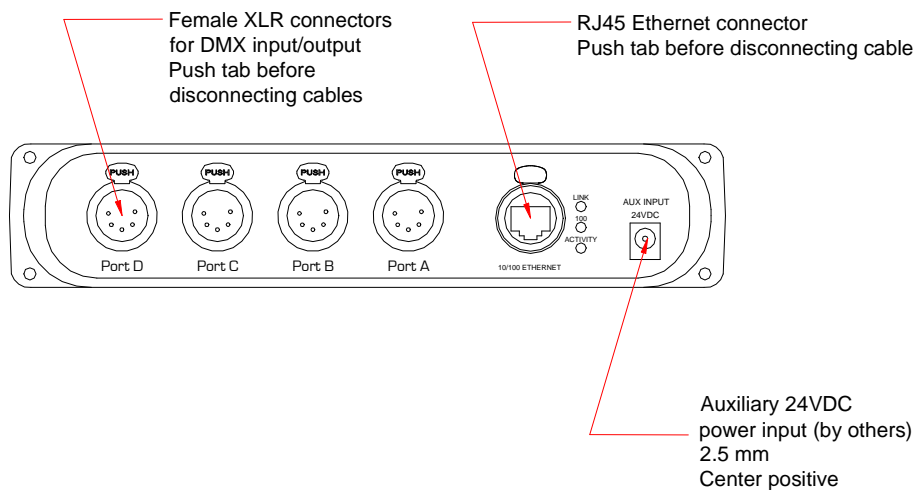

Pathport Quattros are available with female 5-pin XLKR, female 3-pin XLR, RJ45 EtherCon and terminal strip connections for the DMX ports.

## Front Panel Display

The front panel controls of the Quattro allow the user to configure most properties of the node. Current settings are displayed on the LCD screen.

The rotary knob will scroll the screen between base node information and properties of each port. When pushed, the knob also acts as a selector.

By default, the LCD display shows the node name, or soft label, its IP address and subnet class and at the bottom, a flashing “N” when the Quattro detects it is connected to a network via the rear-panel EtherCon port.

```
<Node Name>  
IP: x.x.x.x/<class>  
<N>
```

If no soft-label name has been assigned to the node, the IP address will be shown on the top line as well as the middle. The subnet class, shown after the IP on the middle line, will be “/8”, “/16” or “/24” which are, respectively, a Class A subnet mask of 255.0.0.0, a Class B subnet mask of 255.255.0.0, and a Class C subnet mask of 255.255.255.0.

From the default display, turn the knob to scroll through the Port status screens. A typical port status screen shows the port name or soft label, the port letter and universe patch name, and its DMX status and port direction.

```
<Port Name>  
Port x: <Patch name>  
Status:<state><direction>
```

If no soft-label name has been assigned, “Port <letter>” will be displayed instead.

## Setting Node Properties

With the default display showing, press the encoder knob. The Node Configuration screen will be shown.

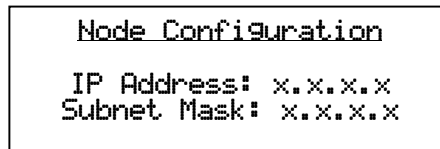

The property available for editing will be highlighted in reverse video. Rotate the knob to scroll through the list of properties. Push the knob to select for editing. The list of choices will be displayed, with asterisks on either side of the current setting. Highlight the desired new setting by rotating the knob and push to select. The asterisks will now appear beside the new setting. Scroll to the bottom of the list and select “<Back>” to return to the previous menu level.

These properties are available from Node Configuration. Further options may be added from time to time:

Property	Explanation	Available Settings
IP Address	Set IP address for node	Select, then turn knob to set each octet. Push to accept.
Subnet Mask	Set subnet mask for node	Select, then turn knob to set each octet. Push to accept.
Default Gateway	Set default gateway for node (Not typically required)	Select, then turn knob to set each octet. Push to accept.
Art-Net Rx (receive)	Set node to listen for Artnet	Enable/Disable
sACN Rx (receive)	Set node to listen for sACN	Enable/Disable
Shownet Rx (receive)	Set node to listen for Shownet	Enable/Disable
Pathport Rx (receive)	Set node to listen for Pathport	Enable/Disable
Tx Data Protocol (send)	Choose transmit protocol	Options are Artnet, sACN, Shownet and Pathport
Firmware Version	Current operating version	Not editable
MAC/Serial number	MAC address/Pathport serial #	Not editable
<Back>	Returns to previous menu	

### Note Regarding ArtNet, Shownet and Subnet Mask

The ArtNet protocol is explicitly sent to a broadcast address, typically 2.255.255.255 or 10.255.255.255. The Quattro must have its subnet mask set wide enough to include this broadcast address. When using ArtNet, a Class A subnet mask of 255.0.0.0 is recommended to ensure DMX output.

Shownet is explicitly sent to 192.168.1.255. On a Shownet system, a Quattro should use an IP of 192.168.1.x and a subnet mask of 255.255.255.0.

## Setting Port Properties

From the Port Status screen of the desired port, push the button. The Port Configuration screen will be shown.

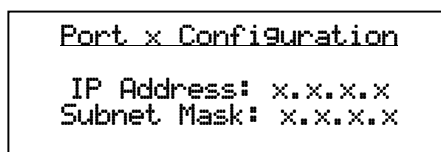

The property available for editing will be highlighted in reverse video. Rotate the knob to scroll through the list of properties. Push the knob to select for editing. The list of choices will be displayed, with asterisks on either side of the current setting. Highlight the desired new setting by rotating the knob and push to select. The asterisks will now appear beside the new setting. Scroll to the bottom of the list and select "<Back>" to return to the previous menu level.

The following properties are available from Port Configuration. Further options may be added from time to time:

Property	Explanation	Available Settings
DMX Port	Turns blue power light on/off	Enable/Disable
Port Direction	Sets DMX direction for port	Input/Output
Patch	Allows selection from a list of standard universe patches	Scroll through choices between 1 and 128, or unpatched
DMX Speed	Sets DMX output speed (no effect on ports set as inputs)	Slow, medium, fast or maximum
<Back>	Returns to previous menu	

## Advanced Configuration

Several node and port properties may only be altered using Pathport Manager software, available on the Pathway website: [www.pathwayconnect.com](http://www.pathwayconnect.com).

Please refer to the Pathport Manager manual for information on these values and how to set them.

Firmware upgrades may only be done using Pathport Manager.

RDM (Remote Device Management) also requires Pathport Manager software.